

ALIGN



TB40

INSTRUCTION MANUAL

輕量化

高強度

安靜 靈活 高效能

TAIL BELT DRIVE

Shopping Cart



TB40 MANUAL



INTRODUCTION	CANOPY ASSEMBLY
前言1	機頭罩安裝24
SAFETY NOTES	SERVO SETTING AND ADJUSTMENT
安全注意事項1	伺服器設定調整25
SAFETY CHECK BEFORE FLYING	ADJUSTMENTS FOR GYRO AND TAIL NEUTRAL SETTING
飛行前安全檢查重要事項3	陀螺儀與尾翼中立點設定調整25
EQUIPMENT REQUIRED FOR ASSEMBLY	MAIN BLADES ROTATIONAL SPEED SETTING
自備設備4	主旋翼轉速設定26
PACKAGE ILLUSTRATION	POWER COLLOCATION REFERENCE
包裝說明4	原裝動力數據參考表26
MODEL STANDARD EQUIPMENT DIFFERENCE	BRUSHLESS SPEED CONTROLLER INSTRUCTION MANUAL
標配版本介紹5	無刷調速器使用說明27
ASSEMBLY SECTION	CHECKLIST AFTER FLIGHT
組裝說明6	飛行後檢查清單28
ELECTRONIC EQUIPMENT ILLUSTRATION	TROUBLESHOOTING
電子設備建議配置圖示23	飛行中狀況排除30
ESC AND SERVO WIRING ILLUSTRATION	TB40 SPECIFICATION COMPARISON TABLE
接線示意圖23	規格對照表31
BATTERY INSTALLATION ILLUSTRATION	
電池安裝示意圖23	

Thank you for purchasing Align products. Please read the manual carefully before installing and be sure to retain the manual for future reference. All pictures shown are for illustration purpose only. Actual product may vary due to product enhancement. Specifications, contents of parts and availability are subject to change, ALIGN RC is not responsible for inadvertent errors in this publications.

承蒙閣下選用亞拓遙控世界系列產品，謹表謝意。

使用前，請務必詳閱本說明書，相信一定能夠給您帶來相當大的幫助，也請您妥善保管這本說明書，以做為日後參考。本公司將不對此印刷物之異動負責，也無法主動通知消費者任何更新或異動。所有圖片僅用於展示目的。產品可能因改良而有些不同。本說明書內記載的材質、規格或零件包裝之內容物如有異動，請依亞拓官網公告為主。

!!Remind!! 提醒

ALIGN

自行拆裝 保固失效
The warranty could
invalid if modified

Dear customers,
For your consumer rights, please do not disassemble or modify Align products. If there is any unauthorized disassembly or modification, the warranty of the product will become invalid immediately! Hereby declare



敬愛的客戶：

為了您的消費權益，本公司所售出之產品請勿自行拆裝、改裝，如果有任何私自拆裝，產品的保修、保固責任即刻失效！特此聲明！

Thank you for buying ALIGN Products. The TB40 Helicopter is designed as an easy to use, full featured Helicopter R/C model capable of all forms of rotary flight. Please read the manual carefully before assembling the model, and follow all precautions and recommendations located within the manual. Be sure to retain the manual for future reference, routine maintenance, and tuning. The TB40 is a new product developed by ALIGN. It features the best design available on the R/C helicopters market to date, providing flying stability for beginners, full aerobatic capability for advanced fliers, and unsurpassed reliability for customer support.

感謝您選購ALIGN產品。為了讓您容易方便的使用亞拓遙控直昇機，請您詳細的閱讀完本說明書之後再進行組裝以及操作遙控直昇機，同時請您妥善的保存這本說明書，作為日後進行調整以及維修的參考。TB40是由亞拓自行研發的新產品，不論您是需求飛行穩定性的初學者或是追求性能飛行愛好者，都是您最佳選擇。

WARNING LABEL LEGEND 標誌代表涵義

	FORBIDDEN 禁止 Do not attempt under any circumstances. 在任何禁止的環境下，請勿嘗試操作。
	WARNING 警告 Mishandling due to failure to follow these instructions may result in damage or injury. 因為疏忽這些操作說明，而使用錯誤可能造成財產損失或嚴重傷害。
	CAUTION 注意 Mishandling due to failure to follow these instructions may result in danger. 因為疏忽這些操作說明，而使用錯誤可能造成危險。

IMPORTANT NOTES 重要聲明

Important Declaration: It's prohibited to fly before passing legal flight certificate (training certificate) of local laws and regulations. Please adhere to local regulation and management policy and pass test to get legal flight certificate (training certificate). Strictly forbid to operate flight by anyone who is unfamiliar with flight experience.

在尚未通過考取該國法規之合格飛行執照（訓練合格證）前，嚴禁實際飛行。請依據該國相關法規及管理辦法，通過考取合法之飛行執照（訓練合格證），嚴禁無熟練操控飛行經驗者操控飛行。

R/C helicopters, including the TB40 are not toys. R/C helicopter utilize various high-tech products and Technologies to provide superior performance. Improper use of this product can result in serious injury or even death. Please read this manual carefully before using and make sure to be conscious of your own personal safety and the safety of others and your environment when operating all ALIGN products. Manufacturer and seller assume no liability for the operation or the use of this product. Intended for use only by adults with experience flying remote control helicopters at a legal flying field. After the sale of this product we cannot maintain any control over its operation or usage.

As the user of this product, you are solely responsible for operating it in a manner that does not endanger yourself and others or result in damage to the product or the property of others.

TB40 遙控直昇機並非玩具，它是結合了許多高科技產品所設計出來的休閒用品，所以產品的使用不當或不熟悉都可能會造成嚴重傷害甚至死亡。使用之前務必詳讀本說明書，勿輕忽並注意自身安全。注意！任何遙控直昇機的使用，製造商和經銷商無法對使用者於操作時使用的損壞或受傷等不當所發生之意外負任何責任。本產品是提供給有操作過模型直昇機經驗的成人或有相當技術的人員在受指導於當地合法遙控飛行場飛行，以確保安全無虞下操作使用。產品售出後本公司將不負任何操作和使用控制上的任何任何安全責任。

做為本產品的使用者，您，是唯一對於您自己操作的環境及行為負全部的責任之人。

We recommend that you obtain the assistance of an experienced pilot before attempting to fly our products for the first time. A local expert is the best way to properly assemble, setup, and fly your model for the first time. TB40 Helicopter requires a certain degree of skill to operate, and is a consumer item. Any damage or dissatisfaction as a result of accidents or modifications are not covered by any warranty and cannot be returned for repair or replacement. Please contact our distributors for free technical consultation and parts at discounted rates when you experience problems during operation or maintenance.

As Allgn Corporation Limited has no control over use, setup, final assembly, modification or misuse, no liability shall be assumed nor accepted for any resulting damage or injury. By the act of use, setup or assembly, the user accepts all resulting liability.

模型產品屬於高精密操作技術且為消耗性之商品，如經拆裝使用後，會造成或不等情況零件損耗，任何使用情況所造成商品不良或不滿意，原裝零件與組件內均無維修或更換之義務。本公司全權分公司或代理商均將提供技術指導、特價零件供應服務。對使用者之不當使用、發聲、維修、修改、或操作，以所造成之損壞或傷害，本公司無法控制及負責。任何使用、發聲、維修、修改、或操作不良所造成的損壞、意外或傷害，使用者應承擔全部責任。

SAFETY NOTES 安全注意事項

- | | |
|--|-------------------|
|  | CAUTION 注意 |
|--|-------------------|
- Fly only in safe areas, away from other people. Do not operate R/C aircraft within the vicinity of homes or crowds of people. R/C aircraft are prone to accidents, failures, and crashes due to a variety of reasons including, lack of maintenance, pilot error, and radio interference. Pilots are responsible for their actions and damage or injury occurring during the operation or as a result of R/C aircraft models.
 - Prior to every flight, carefully check rotorhead, spindle, shaft screws and tail blade grip screws, linkage balls and screws, ensure they are firmly secured.
 - 遙控模型飛機、直昇機屬高危險性商品，飛行時務必遠離人群，人為組裝不當或機件損壞、電子控制設備不良，以及操控上的不熟悉、都有可能導致飛行失控損傷等不可預期的意外，請飛行者務必注意飛行安全，並需了解自負該款型所造成任何意外之責任。
 - 每週飛行前須仔細檢查，主旋翼夾座橫軸螺絲、尾旋翼夾座螺絲，以及機身各部位球頭、螺絲，確實上膠鎖緊才能升空飛行。

**LOCATE AN APPROPRIATE LOCATION 遠離障礙物及人群**

R/C helicopters fly at high speed, thus posing a certain degree of potential danger. Choose a legal flying field consisting of flat, smooth ground without obstacles. Do not fly near buildings, high voltage cables, or trees to ensure the safety of yourself, others and your model. For the first practice, please choose a legal flying field. Do not fly your model in inclement weather, such as rain, wind, snow or darkness.

真昇機飛行時具有一定的速度，相對的也帶着危險性，場地的選擇也相對的嚴苛，請務必遵守當地法規並選擇飛行場地飛行。務必選擇平坦且無障礙物場地，且必須去選擇沒有行人、高樓、電線塔、樹木等等，避免操作的不當造成自己與他人財產的損壞。請勿在下雨、打雷等惡劣天氣下操作，以免傷本身及機器的安全。

**NOTE ON LITHIUM POLYMER BATTERIES 鋰聚電池注意事項**

- Be sure to unplug the battery when storing the helicopter after completing operations, otherwise it may cause damage to the battery due to over-discharge or unexpected accidents such as fire.
- Lithium batteries are dangerous and flammable items. When charging the battery, the operator is strictly prohibited from leaving and staying away from flammable items. Otherwise, the operator will be responsible for all losses caused by any accidents caused.
- 無人機作業完畢後收機時一定要拔除電池，否則可能導致電池過放的損壞或起火燒傷，導致不可預期的意外發生。
- 留意充電場所的環境，充電過程中，務必遠離易燃環境及物品，並確保在可視範圍內進行操作。嚴禁！操作人員離開，否則導致任何的意外，操作者將負其所有造成的損失責任。

**PREVENT MOISTURE 遠離潮濕環境**

R/C models are composed of many precision electrical components. It is critical to keep the model and associated equipment away from moisture and other contaminants. The introduction or exposure to water or moisture in any form can cause the model to malfunction resulting in loss of use, or a crash. Do not operate or expose to rain or moisture.

真昇機內部也是由許多精密的電子零件所組成，所以必須嚴格的防止潮濕或水氣，避免在浴室或雨天時使用，防止水氣進入機身內部導致零件及電子零件故障而引起不可預期的意外！

**PROPER OPERATION 勿不當使用本產品**

Please use the replacement of parts on the manual to ensure the safety of instructors. This product is for R/C model, so do not use for other purpose.

請勿自行拆裝加工，任何的損壞或更換等，請使用原廠高品質的零件，以確保機體的 safety。請務必按照說明書內操作，請勿過載使用，並切勿用於安全、法等外其它非法用途。

**OBTAIN THE ASSISTANCE OF AN EXPERIENCED PILOT 避免獨自操控**

Before turning on your model and transmitter, check to make sure no one else is operating on the same frequency. Frequency interference can cause your model, or other models to crash. The guidance provided by an experienced pilot will be invaluable for the assembly, tuning, trimming, and actual first flight or unforeseen danger may happen. (Recommend you to practice with computer-based flight simulator.)

真昇機飛行前，請確認是否有相同頻率的同站正在飛行，因為頻相近似頻率的假射擊將導致自己與他人立即墜毀等意外危險。請務必確保技巧在學習初期有老一手的指導，避免墜毀或獨自操作飛行，直到經驗的人士在旁指導，才可以讓飛行，否則將可能造成不可預期的意外發生。(動線電腦模擬器及老手指導進入門必做的選擇)

**SAFE OPERATION 安全操作**

Fly only in safe areas, away from crowds of people, do not hold helicopters in front of eyes. During take-off, landing, and flight, be sure to keep the helicopter away from all obstacles. Operators must stand at least 10 meters away from the helicopter to avoid injury caused by loose parts due to improper assembly or any unforeseen dangers. Operate this unit within your ability. Do not fly under tired condition and improper operation may cause in danger. Never take your eyes off the model or leave it unattended while it is turned on. Immediately turn off the model and transmitter when you have landed the model.

嚴禁用手或頭取運行中的真昇機，務必遠離人群，並嚴禁盲目對準眼睛；當主旋翼轉動後，或起飛/試飛時，務必遠離障礙物，站立位置必須距離 10 公尺以上，避免他人為裝裝不當造成零件脫落，而引發不可預期的財物及人員損傷。請於自己能力內及需要一定技術範圍內操作這台真昇機，過於疲勞、精神不佳或不聽操作，意外發生風險將會提高。不可在視線範圍外飛行，既危險也損壞上端地真昇機和遙控器電瓶。

**ALWAYS BE AWARE OF THE ROTATING BLADES 遠離運轉中零件**

During the operation of the helicopter, the main rotor and tail rotor will be spinning at a high rate of speed. The blades are capable of inflicting serious bodily injury and damage to the environment. Be conscious of your actions, and careful to keep your face, eyes, hands, and loose clothing away from the blades. Always fly the model a safe distance from yourself and others, as well as surrounding objects.

真昇機主旋翼與尾旋翼運轉時會以高轉速下運行，在高轉速下的旋翼會造成自己與他人及物件上的嚴重傷痛，請務必隨時注意運轉中的旋翼與環境安全，並保持安全距離以避免造成危險及損傷。

**KEEP AWAY FROM HEAT 遠離熱源**

R/C models are made of various forms of plastic. Plastic is very susceptible to damage or deformation due to extreme heat and cold climate. Make sure not to store the model near any source of heat such as an oven, or heater. It is best to store the model indoors, in a climate-controlled, room temperature environment.

真昇機多半是以 Pa 纖維或聚乙稀、電子元件為主要材質，因此要盡量遠離熱源、日曬，以避免因高溫而造成變形或毀壞機身的可能。



CAREFULLY INSPECT BEFORE REAL FLIGHT 請嚴格執行飛行前之檢查義務



- Before flying, please check to make sure no one else is operating on the same frequency for the safety.
- Before flight, please check if the batteries of transmitter and receiver are enough for the flight.
- Before turn on the transmitter, please check if the throttle stick is in the lowest position. IDLE switch is OFF.
- When turn off the unit, please follow the power on/off procedure. Power ON- Please turn on the transmitter first, and then turn on receiver. Power OFF- Please turn off the receiver first and then turn off the transmitter. Improper procedure may cause out of control, so please to have this correct habit.
- Before operation, check every movement is smooth and directions are correct. Carefully inspect servos for interference and broken gear.
- Check for missing or loose screws and nuts. See if there is any cracked and incomplete assembly of parts. Carefully check main rotor blades and rotor holders. Broken and premature failures of parts possibly cause a dangerous situation.
- Check all ball links to avoid excess play and replace as needed. Failure to do so will result in poor flight stability.
- Check if the battery and power plug are fastened. Vibration and violent flight may cause the plug loose and result in out of control.
- 每次飛行前應先確認所使用的頻率是否會干擾他人，以確保您自身與他人的安全。
- 每次飛行前請先檢查發射器與接收器電池的電量是在足夠飛行的狀態。
- 裝機前應確認門控桿是否位於最低點，熄火開關開關，定速開關 (IDLE) 是否於關閉位置。
- 裝機時必須遵守電源與電機的程序，開機時應先開啟發射器後，再開接收器電源；關機時應先關閉接收器後，再關閉發射器電源。不正確的開機程序可能會造成失控的現象，影響自身與他人的安全，請養成正確的操作習慣。
- 裝機時請先確定直昇機的各個動作是否正確，並檢查每個關節的動作是否有干涉或磨損的情形，使用故障的伺服機將導致不可預期的危險。
- 飛行前應檢查所有缺少或鬆動的螺絲與螺帽，確認沒有組裝不完整或遺漏的零件，仔細檢查主旋翼螺絲有無損壞，特別留意靠近旋翼尖端的部位，螺絲或螺帽不完全的零件不僅影響飛行，更會造成不可預期的危險。注意：每次飛行前的安全檢查、保養、及更換損耗零件，請確實嚴格執行以確保安全。
- 檢查所有的彈簧彈簧是否有鬆脫的情形，鬆動的彈簧彈簧應先更換，否則將造成直昇機無法操作的危險。
- 確認電池及電源線是否固定牢靠，飛行中的震動或激烈的飛行，可能造成電源線鬆脫而造成失控的危險。

INTRODUCTION TO USE OF FUNCTIONAL GLUE/OIL/GREASE 各項功能性膠/油/脂的使用介紹



When you see the marks as below, please use relative glue or grease to ensure flying safety.
標有以下符號之組裝步驟，請配合上膠或上油，以確保膠附零件使用之可靠性。



OIL
潤滑油



CA Glue
瞬間膠



Grease
潤滑油



Anaerobic Retainer
管狀金屬強力結合膠



Thread Lock
螺絲膠

- OIL: Add small amount of OIL.
潤滑油：添加適量潤滑油
- CA: Apply small amount of CA Glue to fix.
瞬間膠：使用適量瞬間膠固定
- Grease: Add small amount of Grease.
潤滑油：添加適量潤滑油
- R48: Apply small amount of Anaerobic Retainer to fix.
管狀金屬強力結合膠：使用適量管狀金屬強力結合膠固定
R48 is strictly forbidden to be used on screws.
R48 嚴禁用於螺絲固定。
- T43: Apply small amount of Thread Lock to fix.
螺絲膠：使用適量螺絲膠



Keep plastic parts away from heat.
塑膠件應避免接近熱源。



When assembling ball links, make sure the "A" character faces outside.
各項膠膠裝組彈簧扣環時，"A"字請朝外。



T43 Glue width: approx. 1mm
T43 上膠寬度約 1mm

- Anaerobic Retainer (R48) is green penetrating threadlocker and is used to fix the metal tube before assembly at temperatures up to +180°C.
 - Thread Lock (T43) is blue low strength threadlocker and is applied to the small screw (threads) or metal parts before assembly to prevent loosening. Ensure to apply only a small amount and wipe surplus off. When disassembling, recommend to heat the metal joint about 15 Seconds.
 - Grease is kind of lubricant additive which is applied to the one-way bearings or thrust bearing.
- Based on parts physical attributes, please apply small amount of the relative glue or grease accordingly to prevent any parts damage or loosening or unexpected danger happened.

- 管狀金屬強力結合膠 (R48) 為綠色液態快速固化的管狀金屬強力結合膠，適合於金屬管狀固定用，可耐高溫至 180°C。
 - 螺絲膠 (T43) 為藍色低強度螺絲膠，適合小型螺絲；使用於金屬內外徑或管狀螺絲時，請務必適量使用，必要時請用手去除多餘膠量，拆卸時可於金屬接合部位熱約 15 秒。
 - 潤滑油 (Grease) 為潤滑劑添加劑，適用於單向軸承及止推軸承。
- 以上各項膠油 (油) 請依零件屬性需求自行準確量取其用量，以達到最佳組裝狀態，避免因使用不當造成零件損壞或不可預期的意外發生。

RADIO TRANSMITTER AND ELECTRONIC EQUIPMENT 自備遙控及電子設備

 <p>Transmitter (8-channel or more, Helicopter system) 發射器 (六動以上直升機模式遙控器)</p>	 <p>Receiver (8-channel or more) 接收器 (六動以上)</p> <p>or</p> <p>Remote Receiver 衛星天線</p>	 <p>Intelligent Balance Charger 智慧型分壓充電器 RCC-4CX</p>
 <p>Flybarless System 無平衡翼系統</p>	 <p>[HETR0001] AP500 Digital Pitch Gauge 數位傾角尺</p> <p>[HETMT901] Multi-function Tester 多功能檢池計</p>	 <p>22.2V 6S 2200mAh Li-Po Battery 電池 x 1</p>

ADDITIONAL TOOLS REQUIRED FOR ASSEMBLY 自備工具

 <p>Phillips Screw Driver 十字螺絲起子 φ 3.0 / φ 1.0mm</p>	 <p>Hexagon Screw Driver 六角螺絲起子 3mm/2.5mm/2mm/1.5mm</p>	 <p>Needle Nose Pliers 尖嘴鉗</p>	 <p>Cutter 刀子</p>	 <p>[H50195] Swashplate Leveler 十字編號正器</p>	 <p>OIL 潤滑油</p>	 <p>CA Glue 瞬間膠</p>
---	--	---	--	---	--	--

PACKAGE ILLUSTRATION 包裝說明

<p>Parts Pack 配件包</p> <p>40H01 40T03</p>	<p>Carbon Fiber Blades x 1set 碳纖維主旋翼 x 1組</p> <p>Carbon Fiber Tail Boom x 1 碳纖維尾管 x 1</p>	<p>The Top Combo version includes the following items Top Combo版本包含以下商品</p> <p>400MX(1100KV/3220) Motor 400MX(1100KV/3220)無刷馬達 x 1</p> <p>Microbeast Flybarless System Microbeast無平衡翼系統 x 1</p> <p>60A Brushless ESC 60A無刷调速器 x 1</p> <p>DS450M Digital Servo DS450M數位伺服器 x 3</p> <p>DS535M Digital Servo DS535M數位伺服器 x 1</p>
<p>Parts Pack 配件包</p> <p>40B01 40B02 40B03 40B04 40F01 40T01 40T02 40C01 40Z01</p>	<p>Lube Pack 潤滑油包</p> <p>Thread Lock T43螺絲膠 x1</p> <p>One Way Bearing Grease 單向軸承潤滑油 x1</p> <p>Canopy 機頭罩</p> <p>Repair Towel 維修毛巾</p>	<p>The Kit version includes the following items Kit 版本包含以下商品</p> <p>400MX(1100KV/3220) Motor 400MX(1100KV/3220)無刷馬達 x 1</p>

There are many versions of TB40 for your choice. The Combo includes additional electronics and other equipment. The Instruction Manual will refer to the TB40 Top Combo. You may purchase any additional items referenced in the instruction manual or any spare parts for other TB40 version by referring to more product information in this manual.

TB40系列商品有多種版本可作為選擇，除標準配備會因您購買的商品版本而有些微不同，在組裝、設定上都是一致的，在此我們以 Top Combo 作為操作範例，您也可依照書面上的商品圖錄來增添其他選購商品。

Quick Finder
零件快選購



TOP COMBO STANDARD EQUIPMENT TOP COMBO 標準配備 [RH40E01XT]



- TB40 Kit x1 set
- TB40 空機套件組
- 400MX(1100KV/3220) Motor
- 400MX(1100KV/3220) 無刷馬達 x 1
- Microbeast Flybarless System
- Microbeast 無平衡翼系統 x 1
- 60A Brushless ESC
- 60A 無刷调速器 x 1
- DS450M Digital Servo
- DS450M 數位伺服器 x 3
- DS535M Digital Servo
- DS535M 數位伺服器 x 1

KIT STANDARD EQUIPMENT KIT 標準配備 [RH40E06XT]



- TB40 Kit x1 set
- TB40 空機套件組
- 400MX(1100KV/3220) Motor
- 400MX(1100KV/3220) 無刷馬達 x 1

ELECTRONIC EQUIPMENT REQUIRED FOR ASSEMBLY 自備電子設備



Microbeast Flybarless System
無平衡翼系統 x 1



60A Brushless ESC
60A 無刷调速器 x 1



DS450M Digital Servo
DS450M 數位伺服器 x 3



DS535M Digital Servo
DS535M 數位伺服器 x 1

ROTORHEAD 主旋翼頭組

40H

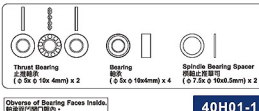
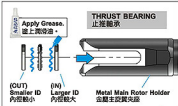

40H01-1



Please follow the instruction of Thrust bearing: "IN" faces inward, "OUT" faces outward; Assembly in the wrong direction can cause interference, improper operation, and unpredictable danger.

請依止推軸承字樣指示: "IN"面向內側, "OUT"面向外側; 裝反方向錯誤會造成干涉、運作不順或危險。



Thrust bearing and spindle damper for radial bearing are wear items; therefore, it is recommended to inspect after every 20 flights and replaced as necessary.

止推軸承及軸承止推墊圈屬於飛行消耗品, 建議每 20 趟定期檢查及更換。

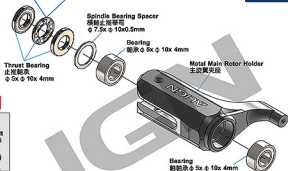

Logo on the top
字樣朝上



The spindle and spindle socket screws are wear items, and thus should be inspected for replacement after every 100 flights. For flights with high head speed, the inspection interval should be reduced to ensure flight safety.

主旋翼軸承銷、或軸承插銷螺絲屬於飛行消耗品, 建議每 100 趟定期檢查及更換。主旋翼高轉速飛行時, 請縮短定期檢查之週數, 以確保飛行安全。

Original manufacturer packages contains product already assembled, before flying, please check if the screws are fixed with T43.

原廠零件包裝盒內產品若已組裝, 第一次飛行前請先確認螺絲是否已上膠不會鬆動。



Apply a small amount of T43 thread lock when fixing a metal part.
Do not use T43 on any plastic part.

螺絲鎖附於金屬件請使用適量 T43 (螺絲膠), 請注意 T43 不可塗在任何的塑膠材質上。



Please apply a small amount of T43 when tightening the spindle socket screws and make sure to tighten firmly, but not over tighten. Suggest using a torque wrench or torque lock when tightening screws. Torque value 20.0kg·cm 螺絲鎖附於時需注意鎖附之緊度與使用適量的螺絲膠, 建議搭配扭力扳手或扭力機鎖附螺絲, 鎖定扭力值為 20.0kg·cm。



3D flight 100 times or serious crash may cause metal fatigue or damaged. Please check and replace the Collar Screw.

暴力飛行 100 趟或出現嚴重撞車, 可能有金屬疲勞、破壞疑慮, 請務必檢查更新螺絲鎖。

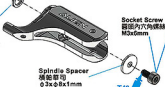

SWASHPLATE/MAIN SHAFT 十字盤組/主軸

40H01

Socket Button Head Screw
半圓頭內六角螺絲 (#0-09x4mm) x 4

Socket Screw
圓頭內六角螺絲 (M2x10mm) x 2

Bearing
軸承 (φ1.5xφ4x2mm) x 4

Bearing
軸承 (φ2xφ5x2.3mm) x 4

Washer
華司 (φ2xφ3.6x0.2mm) x 2

Linkage Ball A
球頭 A (M2x3) (φ4.75x10.1mm) x 2

Linkage Ball B
球頭 B (M2x2.8) (φ4.75x7.46mm) x 4

Long Linkage Ball
導板用球頭 (M2x3) (φ4.75x25mm) x 1



Original manufactory packages contains product already assembled, before flying, please check if the screws are fixed with T43.



Apply a small amount of T43 thread lock when fixing a metal part.
Do not use T43 on any plastic part.

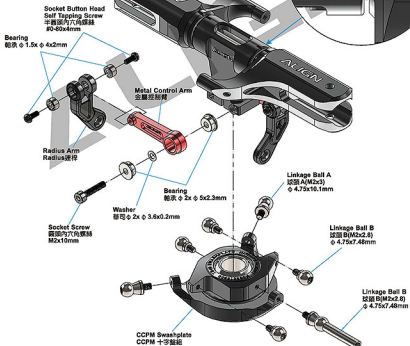
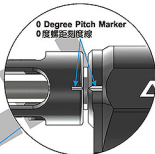



M2.5 Nut
M2.5 防鬆螺帽 x 2



Socket Collar Screw
適配內六角粗牙螺絲 (M2.5x15mm) x 2



Linkage Ball A (M2.5x3)
球頭 A (φ 4.75x9.77mm) x2



Original manufactory packages contains product already assembled, before flying, please check if the screws are fixed with T43.



Apply a small amount of T43 thread lock when fixing a metal part. Do not use T43 on any plastic part.

40H01-1

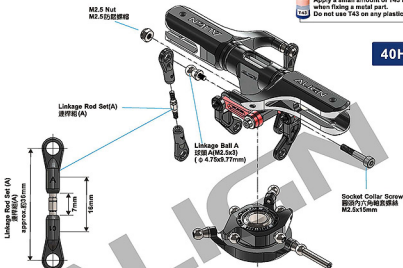

Linkage Rod Set (A)
連桿組 (A)
approx. 約36mm

Linkage Rod Set (A)
連桿組 (A)

Linkage Ball A
球頭 A (M2.5x3)
(φ 4.75x9.77mm)

Socket Collar Screw
適配內六角粗牙螺絲
M2.5x15mm

Main Shaft
主軸 φ 5x φ 8x106.1mm



For installation, make sure the "Check Point" is face upward, then use pillar or wrench grasp the center of hexagonal rod to adjust its suitable length, turns clockwise to decrease the length, turns counter clockwise to increase the linkage length.

You may adjust the length of ball link to adjust blade tracking.

組裝時請將連桿中裝有溝槽的一面朝上。請使用尖嘴鉗或扳手將連桿中裝六角柱部位適量調整長度，順時針轉動為調整連桿長度；逆時針轉動則為增加連桿長度。

若飛行中有變態情形，可調整調整連桿長度改善。



Left-hand
定轉

Check Point
溝槽標尺

Right-hand
定轉

Optional Equipment
選配品

Swashplate Leveler
十字盤校正器
[H50195]

Horizontally Level
水平



While using Flybarless system, please use the swashplate leveler to calibrate swashplate. Adjust the length of servo linkage rod to make sure the swashplate is leveled before start setting up to ensure the gyro provides the best performance.

使用無桿系統，請務必使用十字盤調整器校正十字盤，調節調整連桿長度，調整十字盤達到水平狀態，再進行及不機體配定，這樣才能確保飛行性能達到最佳效果。

1. Main rotor head and main shaft are wear items; it is recommended to inspect after every 200 flights and replace as necessary. For high headspeed flights, the inspection interval should be reduced to ensure flight safety.
2. Make sure to check and change the parts in any failure due to normal deterioration or mechanical wear to prevent expected danger during high headspeed flight.

1. 旋翼頭組及主軸屬於飛行消耗品，建議每200次定期檢查及更換，請縮短定期檢查之週數，並根據實際情況進行調整，以確保飛行安全。

2. 若發生人為組裝不當或機件磨損造成機型產品損壞時，請務必詳細檢查，強烈建議更換損壞的部件，避免與定設置轉速飛行時，發生不可預期的意外。

BODY 機身組

40B

It is recommended to use # 800-1000 water sandpaper to polish the edge of the cutting part of the fuselage board. This way could prevent the wires of electronic equipment from being cut.

建議於機身板切割處的邊緣，使用#800-1000水砂紙打磨，可防止電子設備電線被割破。

Waterproof Abrasive Paper
水砂紙(#800-1000)



40B02-1

40B03

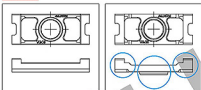

Front Drive Shaft
Bearing Housing
前傳動軸軸承座

Bearing
軸承
 $\phi 6x\phi 10x3mm$

3rd Bearing Block
第三軸承座

Upper Main Frame(R)
上機板(右)

ESC Mount
ESC 固定板

Aluminum Hex
Frame Bolts
六角機身螺栓

Socket Button Head
Self Tapping Screw
半圓頭內六角自攻螺絲
T2.6x8mm

Socket Screw
圓頭內六角螺絲
M2.5x8mm

Original manufactory packages contains product already assembled, before flying, please check if the screws are fixed with T43.



Apply a small amount of T43 thread lock when fixing a metal part.
Do not use T43 on any plastic part.

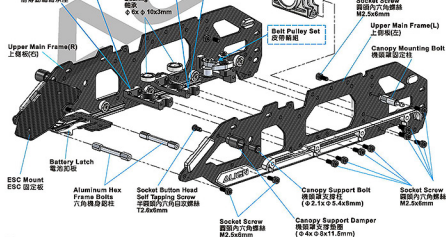

40T01

TAIL BOOM MOUNT SET 尾管固定座組

40B02

40T01

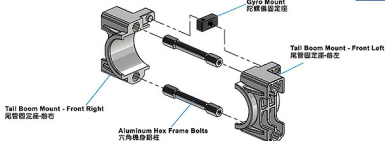

BELT PULLEY SET 皮帶輪組

40B03

- Socket Screw
圓頭內六角螺絲 (M2x14mm) x1
- Socket Button Head Screw
半圓頭內六角螺絲 (M2x8mm) x2
- Bearing
軸承 (φ2x φ4.5x2mm) x4
- Washer
碟形墊圈 (φ2x φ3.6x0.5mm) x2
- Bearing
軸承 (φ3x φ7x3mm) x2

Facet cutout for Belt Tensioner Bolt, please fit against the Main Frame.
皮帶壓緊柱的小平面切口，請與機身嵌合固定。

The Belt Tensioner Spring should be inserted into the inner hole position of the Belt Pulley Arm.
皮帶彈簧須插入皮帶壓輪臂內孔位置。

During the flight, the Belt Pulley Arm will timely give pressure according to the belt tightness, in order to make the flight more smooth. Please pay attention to the Belt Pulley Arm position. It should be adjusted to correct rest position to function properly.

Adjust the tension of the Tail Belt as depicted on page 21, until the belt tensioner reaches a flat position. During the flight, the Belt Tensioner works to maintain a constant tension applied on the Tail Belt.
皮帶壓輪臂在飛行過程中，針對皮帶鬆緊度的改變，適時的給予壓力，使飛行更順暢。所以請注意，皮帶壓輪臂在靜止的位置，才能確實地發揮功能。

如第 21 頁所述調整尾帶的張力，直到皮帶壓輪臂達到平坦位置。在飛行過程中，皮帶張緊器用於保持施加在尾帶上的恆定張力。

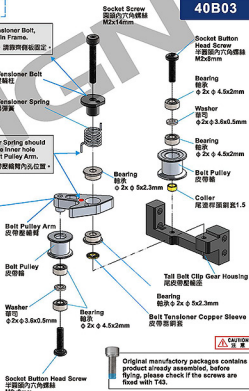
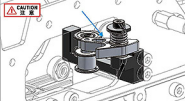

CAUTION 注意
Original factory packages contains product already assembled, before flying, please check if the screws are fixed with T43.

CAUTION 注意
Apply a small amount of T43 thread lock when fixing a metal part. Do not use T43 on any plastic part.

40B04



Washer
華司 (φ6xφ9x1mm) x1



Socket Screw
圓頭內六角螺絲 (M2.5x6mm) x3



Phillips Flat Head Self Tapping Screw
圓頭十字自攻螺絲 (T1.5x4mm) x3



Bearing
軸承 (φ6xφ10x3mm) x1



Bearing
軸承 (φ8xφ14x5mm) x2



Bearing
軸承 (φ8xφ12x3.5mm) x1



40B04

Belt Pulley Assembly 皮帶輪組 40T

Special lubricating oil (silicone oil) for one-way bearings must be added during assembly. After 60-100 flights, be sure to disassemble and maintain and add lubricating oil to avoid one-way bearings slipping during flight.

組裝時，必須添加單向軸承專用(矽油)潤滑油，每飛行60-100趟後，務必拆開保養並添加潤滑油，以避免飛行中單向軸承產生打滑。

Apply Grease.
塗上面滑油。



One-way Bearing
單向軸承
φ6xφ12x10mm

Belt Pulley 40T
皮帶輪40T

Bearing
軸承
φ8xφ12x3.5mm

Tail Drive Belt Pulley Assembly
尾傳動皮帶輪組 25T



Tail Drive Belt Pulley
尾傳動皮帶輪25T



Tail Drive Belt Pulley cover 25T
尾傳動25T皮帶輪蓋



Phillips Flat Head Self Tapping Screw
圓頭十字自攻螺絲
T1.5x4mm

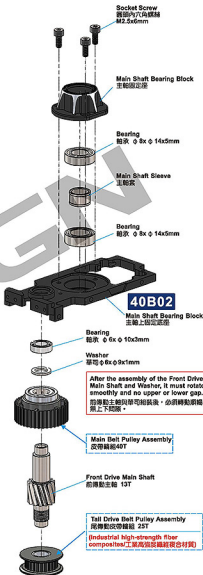

Socket Screw
圓頭內六角螺絲
M2.5x6mm

Main Shaft Bearing Block
主軸固定座

Bearing
軸承 φ8xφ14x5mm

Main Shaft Sleeve
主軸套

Bearing
軸承 φ8xφ14x5mm

40B02

Main Shaft Bearing Block
主軸上固定座

Bearing
軸承 φ6xφ10x3mm

Washer
華司 φ6xφ9x1mm

After the assembly of the Front Drive Main Shaft and Washer, it must rotate smoothly and no upper or lower gap. 前傳動主軸與華司組裝後，必須轉動順暢無上下間隙。

Main Belt Pulley Assembly
皮帶輪組40T

Front Drive Main Shaft
前傳動主軸 13T

Tail Drive Belt Pulley Assembly
尾傳動皮帶輪組 25T

(Industrial high-strength fiber composite) 工業高強纖維複合材料

40B02

40B04

Signal Wire Notch(L)
訊號線槽(左)Insert the signal cable
trough into the fuselage.
將訊號線槽卡入機身。

40B03

150-2GT Belt
150-2GT 皮帶

40B03

1110-2GT Belt
1110-2GT 皮帶Socket Screw
圓頭內六角螺絲
M2.5x6mmTail Rudder Servo Mount
尾舵舵機固定座Socket Screw
圓頭內六角螺絲
M2.5x6mmLinkage Ball B
球頭B(M2x2.0)Servo Horn
舵機臂

Tail Rudder Servo Horn
Use the inner Hole
尾舵舵機臂鎖固於內孔。

Collar
鋼套Washer
帶孔 $\phi 2.6 \times \phi 5.8 \times 0.6 \text{mm}$ Socket Screw
圓頭內六角螺絲
M2.5x16mm

40SD01

DS535M Digital Servo
DS535M 數位伺服器1520 μs Standard Band / 1520 μs 寬頻系統

Stall Torque/ 輸出扭力	5.0kg.cm(6.0V) 6.5kg.cm(8.4V)
-----------------------	----------------------------------

Motion Speed/ 動作速度	0.050sec/60° (6.0V) 0.035sec/60° (8.4V)
-----------------------	--

Dimension/尺寸	35.1 x 15.1 x 29mm
--------------	--------------------

Weight/重量	36g
-----------	-----



Original factory packages contains
product already assembled, before
flying, please check if the screws are
fixed with T43.



Apply a small amount of T43 thread lock
when fixing a metal part.
Do not use T43 on any plastic part.

450HSD05

40Z02

DS450M Digital Servo
DS450M 數位伺服馬達1520 μ s Standard Band / 1520 μ s 寬頻系統

Stall Torque/ 輸出扭力	3.0kg.cm (6.0V) 4.0kg.cm (8.4V)
Motion Speed/ 動作速度	0.06sec/60° (6.0V) 0.05sec/60° (8.4V)
Dimension/ 尺寸	23 x 12 x 31.3mm
Weight/ 重量	20g

First lock the front servo mount on the fuselage, and then assemble and secure the servo.

先將前伺服馬達固定座鎖在機身上，再將伺服馬達組裝固定。

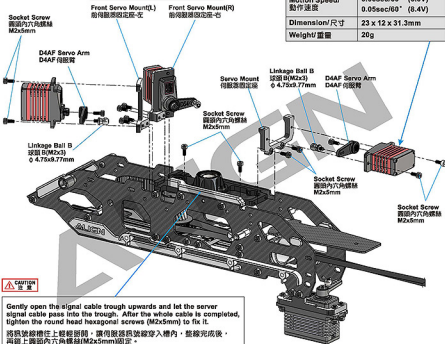

Gently open the signal cable trough upwards and let the server signal cable pass into the trough. After the whole cable is completed, tighten the round head hexagonal screws (M2x5mm) to fix it.

將訊號線槽往上輕輕扳開，讓伺服訊號線穿入槽內，並線完成後，再鎖上圓頭內六角螺絲(M2x5mm)固定。



Original manufacturer packages contains product already assembled, before flying, please check if the screws are fixed with T43.



Apply a small amount of T43 thread lock when fixing a metal part. Do not use T43 on any plastic part.



Linkage Ball B
球頭B(M2x3) ϕ 4.75x9.77mm X3



Socket Screw
圓頭內六角螺絲(M2x5mm) x12

40B02

40T01

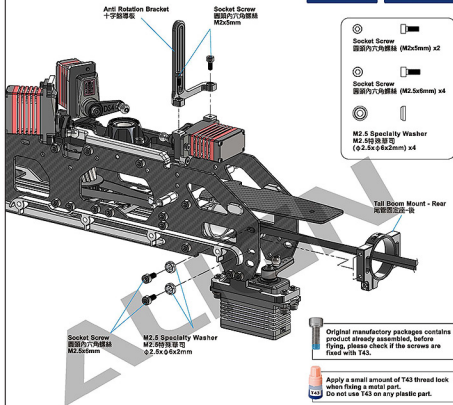

Main frame assembly key point :

First do not fully tighten the screws of main frames and put two bearings through the main shaft to check if the movements are smooth. The bottom bracket must be firmly touched the level table top(glass surface) ; please keep the smooth movements on main shaft and level bottom bracket, then slowly tighten the screws. This assembly can help for the power and flight performance.

機身側板組立重點：

側板螺絲先不完全鎖緊，放入主軸貫穿兩顆軸承確認上下移動必需滑順，主軸底板必須與水平桌面（玻璃平面）確實緊貼；請保持主軸滑順與底板平行桌頂後慢慢鎖緊螺絲，正確安裝的組裝對動力與飛行性能有顯著幫助。

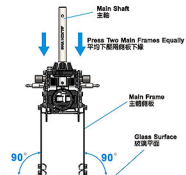



Original manufactory packages contains product already assembled, before flying, please check if the screws are fixed with T43.



Apply a small amount of T43 thread lock when fixing a metal part. Do not use T43 on any plastic part.

40B01

40B01-1

- 

Socket Screw
圓頭內六角螺絲 (M2.5x12mm) x8
- 

Socket Screw
圓頭內六角螺絲 (M2.5x6mm) x4

Lower Main Frame
下機架

Socket Screw
圓頭內六角螺絲
M2.5x12mm

Socket Screw
圓頭內六角螺絲
M2.5x6mm

Landing Set
腳架組

LANDING SET 腳架組

40F01

- 

Socket Screw
圓頭內六角螺絲 (M2.5x6mm) x4

Landing Skid Mount
腳架固定座

Landing Skid Mount
腳架固定座

Socket Screw
圓頭內六角螺絲
M2.5x6mm

Socket Screw
圓頭內六角螺絲
M2.5x6mm

40B04

Motor Belt Pulley Assembly
馬達皮帶輪組 22T

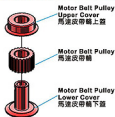

Socket Button Head Screw
半圓頭內六角螺絲 M3x6mm

When locking the screw to Motor Belt Pulley, must use the glue and make sure you slightly lock it tight.
鎖附馬達皮帶輪的止滑螺絲時，務必點膠並適當用力鎖緊。

M3 Set Screw
M3 止滑螺絲 M3x6mm

Motor Mount
馬達固定座

Motor
馬達

Be sure to align the Motor Belt Pulley Assembly with the groove of the motor spindle, or the belt won't be in a horizontal position.
組裝時，務必將馬達皮帶輪組，對齊馬達心軸的溝槽位置；否則會導致皮帶歪斜。



- M3 Set Screw
M3 止滑螺絲 (M3x6mm) x2
- Socket Button Head Screw
半圓頭內六角螺絲 (M3x6mm) x4

Motor Belt Pulley 馬達皮帶導輪

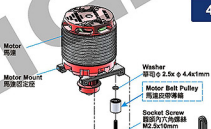

40B02

Attention! Please adjust to a proper tightness when assembling Motor Drive Belt. If it's too loose, it will easily cause the pulley to slip. Also pay attention to tighten the screws of the motor mount.

請注意！馬達傳動皮帶，組裝時請調整適當緊度，過鬆容易導致皮帶磨打滑，並注意鎖緊馬達固定螺絲。

- Bearing
軸承 ($\phi 2.5x \phi 6x2.6mm$) x2
- Washer
墊圈 ($\phi 2.5x \phi 4.4x1mm$) x2
- M2.5 Specialty Washer
M2.5特製墊圈 ($\phi 2.5x \phi 6x2mm$) x4
- Socket Screw
圓頭內六角螺絲 (M2.5x6mm) x4
- Socket Screw
圓頭內六角螺絲 (M2.5x10mm) x1

M2.5 Specialty Washer
M2.5特製墊圈
 $\phi 2.5x \phi 6x2mm$

Socket Screw
圓頭內六角螺絲
M2.5x6mm

TAIL 尾部組

40T

When assembling the tail boom ensure the boom is properly installed in the tail boom mount and check to make sure belt is in the correct position.

尾管組裝時必須確實頂住尾管固定座，以確保皮帶調整位置正確。



Original manufacturer packages contains product already assembled, before flying, please check if the screws are fixed with T43.



Apply a small amount of T43 thread lock when fixing a metal part. Do not use T43 on any plastic part.

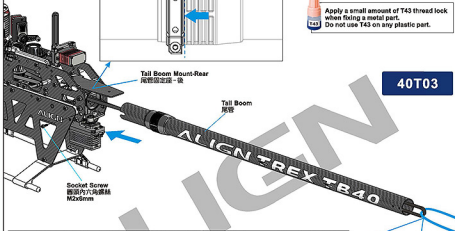

40T03

Use a string or flexible wire to pull the belt through the boom. Feed one end through the boom, loop through belt and feed back through the boom. Gently pull both ends of the string or wire until the belt is completely pulled through the boom. Please refer to the diagram below. Confirm the belt is installed correctly and not turned more than 90 degrees. Improper installation of the belt can result in serious damage to the helicopter or people.

建議使用繩線或柔性導線將皮帶穿過尾管。將皮帶一端穿過尾管，繞過皮帶並穿回尾管。輕輕拉動繩線或導線兩端，直到皮帶完全穿過尾管。請參閱下方圖示。確認皮帶安裝方向正確，否則將發生不可預期的危險。

DRIVE BELT ILLUSTRATION

尾傳動皮帶裝配圖示

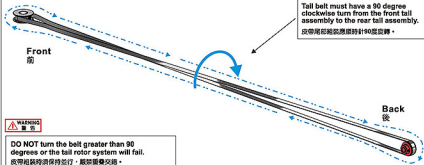

Tail belt must have a 90 degree clockwise turn from the front tail assembly to the rear tail assembly.

皮帶尾端必須應順時針90度旋轉。



DO NOT turn the belt greater than 90 degrees or the tail rotor system will fail.

皮帶組裝時請保持並行，嚴禁重疊交錯。

40T02

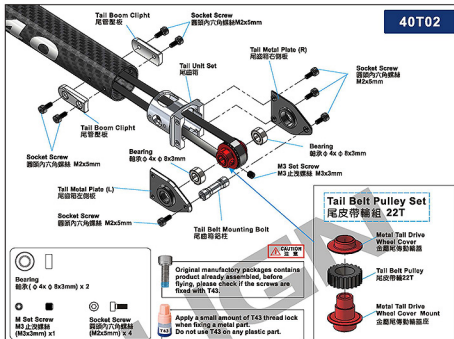

Tail Pitch Control Set 尾控制組

40T02

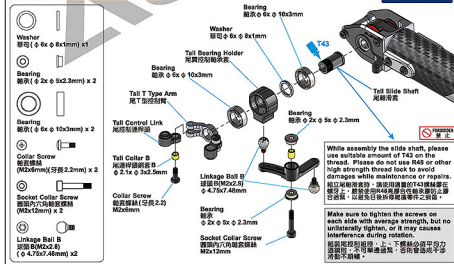

40T02



Original manufacture packages contains product already assembled, before flying, please check if the screws are fixed with T43.

Apply a small amount of T43 thread lock when fixing a metal part. Do not use T43 on any plastic part.

70 Tail Blades
70 尾旋翼

CAUTION 注意

The Metal Tail Rotor Holder is assembled at the factory, make sure to apply little thread lock on screws and tighten them back appropriately before starting to fly. Suggest to use torque wrench or torque lock for tightening screws with the torque value 4.0kg.cm.

尾旋翼夾座出廠為預裝好，螺絲必須帶些潤滑螺絲膠，膠層薄且透明，裝好後注意適當旋緊即可。建議用配扭力扳扭力鎖緊螺絲，扭力值為4.0kg.cm。

M2.5 Nut
M2.5 防鬆螺母

Socket Collar Screw
圓頭內六角螺絲 M2.5x15mm

Socket Screw
圓頭內六角螺絲 M2.5x6mm

The screws at both ends of the T-mount shaft must be dotted with screw glue and then locked. Please tight the screw with a low torque.

尾旋翼T形架的高強度螺絲動上螺絲膠後固定，固定好後輕力擰緊，使尾旋翼夾座轉動無聲即可。

Apply Grease. 塗上潤滑油。

Thrust Bearing
止推軸承
 $\phi 4x \phi 8x3.3mm$

(OUT) Smaller ID 內徑較小
(IN) Larger ID 內徑較大

Tail Rotor Holder
尾旋翼夾座

Washer
碟形墊圈
 $\phi 2.6x \phi 5.8x0.6mm$

Bearing
軸承
 $\phi 4x \phi 8x3mm$

Tail Rotor Holder Washer
尾旋翼座碟形墊圈
 $\phi 6x \phi 8x0.3mm$

Tail Rotor Holder Washer
尾旋翼座碟形墊圈
 $\phi 4x \phi 5.8x0.3mm$

Bearing
軸承
 $\phi 4x \phi 7x2.5mm$

Oil seal
油封
 $\phi 3.8x \phi 7.6x1.5mm$

Tail rotor T-shaped Mount
尾旋翼T型架螺絲

Socket Button Head Screw
平頭圓頭內六角螺絲 M2x5mm

Tail Collar
尾旋翼座鎖緊圈
 $\phi 2.3x \phi 3x1.5mm$

Tail Spindle
尾旋翼軸

Tail Rotor Holder Washer
尾旋翼座碟形墊圈
 $\phi 6x \phi 8x0.3mm$

When assembling the metal washer on the tail T-shaped Mount, the sharp side should face outward and not face the Oil seal, otherwise the Oil seal will be easily scratched.

尾T型架在裝好金屬碟形墊圈時，銳利側面朝外，不能朝內密封，否則容易刮到油封。

Tail Rotor Hub
尾旋翼T型座
 $\phi 4.2x \phi 9.8x0.6mm$

M3 Set Screw
M3 止鎖螺絲 M3x3mm

CAUTION 注意

Make sure to tighten the screws on each side with average strength, but no unilaterally tighten, or it may cause interference during rotation.

旋翼控制組裝時，上、下螺絲必須平均力擰緊，不可單邊過緊，否則會造成干涉導致不順轉。

CAUTION 注意

After complete the tail rotor assembly, please check if it rotates smoothly.

尾旋翼組裝完成後請確認尾旋翼夾座轉動順暢。

CAUTION 注意

Aim tail rotor hub at the concave of the tail spindle and apply thread lock on the set screw. The tail rotor hub and screws are wear items, and thus should be inspected for replacement after every 100 flights. For flights with high head speed, the inspection interval should be reduced to ensure flight safety.

尾旋翼T型座應準確尾旋翼軸的凹形並鎖上，請確認止鎖螺絲上緊。尾旋翼T型座和螺絲屬於飛行消耗品，建議每100 固定間檢查及更換，高主旋翼轉速飛行時，請縮短檢查間隔之次數，以確保飛行安全。

40B04



Original manufacturer packages contains product already assembled, before flying, please check if the screws are fixed with T43.



Apply a small amount of T43 thread lock when fixing a metal part. Do not use T43 on any plastic part.

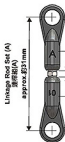

Linkage Rod Set (A)
連桿組(A)

Main shaft spacer
主軸墊片
φ8xφ10x0.2mm

When the Swashplate is adjusted horizontally (0 degree), the Swashplate Linkage Rod must be centered at the midpoint of the Anti Rotation Bracket. If the offset is large and a large cycle pitch is set, there might be a travel interference.
十字盤調整水平(0度時), 十字盤連桿必須置中在十字盤旋轉中點位置。如果偏移量大且設定大循環螺距時, 可能有行程干涉。

Midpoint
中點位置

Socket Collar Screw
插頭六角鎖緊螺絲
M2.5x15mm

M2.5 Nut
M2.5 螺帽

Silent Thread
Main Drive Gear 46T
靜主齒輪 46T



General 3D sport flight recommended! The Main Gear is a consumable product, please check and replace the main gear after 100 flights.
主齒輪屬消耗品, 一般3D飛行, 每100週, 建議注意檢查並更換齒輪。



Install the main shaft into the main drive gear after the belt has been installed, then align main shaft with the main shaft mounting sleeve, insert screw and tighten. DO NOT over tighten as this may cause damage of main shaft mounting sleeve.
請將組裝完成之主軸穿入已裝送皮帶的靜主齒輪, 穿入相對準主齒固定套上的孔位對齊, 並以適當扭力鎖附即可, 過度鎖緊易造成主齒固定套磨牙。



Socket Collar Screw
插頭六角鎖緊螺絲
(M2.5x15mm) x 1

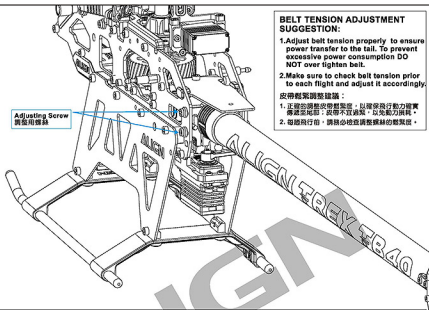

M2.5 Nut
M2.5 的螺帽 x 1

**BELT TENSION ADJUSTMENT SUGGESTION:**

1. Adjust belt tension properly to ensure power transfer to the tail. To prevent excessive power consumption DO NOT over tighten belt.
2. Make sure to check belt tension prior to each flight and adjust it accordingly.

皮帶鬆緊調整建議：

1. 正確調整皮帶鬆緊度，以確保飛行動力確實傳遞至尾部；皮帶不宜過緊，以免動力損耗。
2. 每趟飛行前，請務必檢查調整螺絲的鬆緊度。

PATENTED DESIGN

專利設計

ADJUSTABLE BELT TENSION DESIGN / 可調節皮帶張力設計

The Upper Main Frame cleverly inserts a rail, simply by turning a few screws, then allows the belt tension to adjust conveniently.

上機板巧妙地插入軌道，只需轉動幾顆螺絲，即可方便地調節皮帶張力。

ADJUSTING WAY 調整方式

Make sure to check belt tension prior to each flight and adjust accordingly. Both sides must be rotated equally.

注意：調整時務必將兩側的調整螺絲同時放鬆或鎖緊。

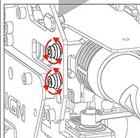

1. First loosen the screws on the two sides of the Upper Main Frame.

1. 先鬆開機身上側板外兩邊的調整螺絲。

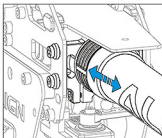

2. Then adjust the tail pipe to the proper position.

The tail pipe will tighten the belt backward.

The tail pipe will loosen the belt forward.

2. 然後將尾管調整至適當位置。

尾管固定座及尾管往後拉緊皮帶。

尾管固定座及尾管往前放鬆皮帶。

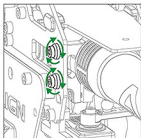

3. After adjusting to the proper tightness, tighten the fixing screw.

3. 調整適當鬆緊度後，再將調整螺絲鎖緊即可。



When tightening the main blade fixing screw, please tighten it firmly, but not over tighten, or it may cause the damage of main blade holder and result in danger.

鎖緊主旋翼螺絲時請適當緊度即可，過緊可能導致主旋翼夾座受損，飛行意外發生。

40H01
470HH2

Main Blade Fixing Screw
鎖主旋翼用螺絲



Socket Collar Screw
圓頭內六角鎖緊螺絲 (M3x17mm) x 2

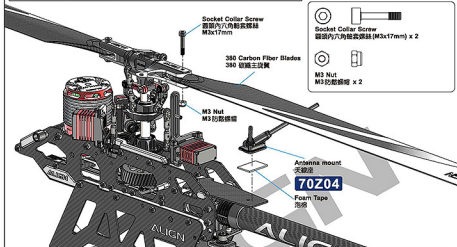

M3 Nut
M3 防鬆螺帽 x 2

40T02
40T03

Socket Screw
圓頭內六角螺絲 (M2x8mm) x 2

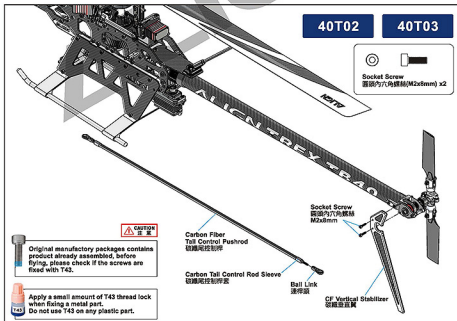

Original manufactory packages contains product already assembled, before flying, please check if the screws are fixed with T43.



Apply a small amount of T43 thread lock when fixing a metal part.
Do not use T43 on any plastic part.

ELECTRONIC EQUIPMENT ILLUSTRATION

電子設備建議配置圖示

ALIGN

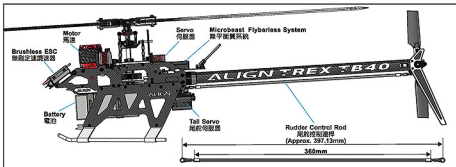

ESC AND SERVO WIRING ILLUSTRATION 接線示意圖

ALIGN

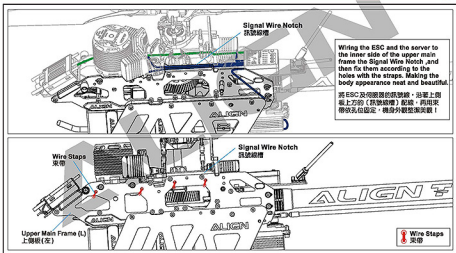

BATTERY INSTALLATION ILLUSTRATION 電池安裝示意圖

ALIGN

40B02



Please strictly abide by the precautions for use in the lithium-polymer battery manual. Improper use of lithium-polymer batteries may cause fire and damage life and property safety. Do not be careless! 請嚴格遵守鋰聚合物電池說明書之使用注意事項，切勿疏忽使用鋰電池，可能造成火災並傷及生命財產安全，切勿大意！

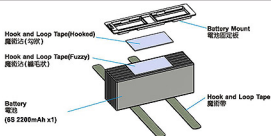

INSERT THE BATTERY FROM THE FRONT

前置式電池滑軌設計

New 3K Main frame embedded with battery mounting rails with patented spring loaded latching mechanism.

3K 機框與電池滑軌一體成型，整合式彈壓結構增加卡榫設計。

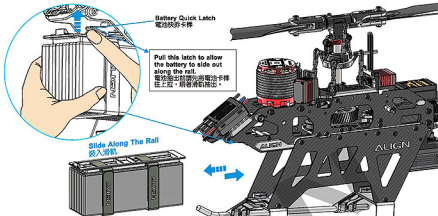

Slide the battery mounting plate along the rail until a "click" is heard to make sure the battery mounting plate is latched.

將電池固定板順著電池滑軌裝入至發出“嗒嗒”聲響，使電池固定板卡入卡榫。

CANOPY ASSEMBLY 機頭罩安裝

Advanced Lightweight Canopy
高強度輕量化機頭罩

40C01



Quick release latch design
卡式快速拆換設計



When assembling the canopy to the unit, please completely wedge into the groove of the bottom plate.
機頭罩鉤裝於機體時，請完全卡入主體底板的溝槽內。



To set this option is to turn on the transmitter and connect to BEC power.

Note: For the safety, please do not connect ESC to the brushless motor in order to prevent any accident caused by the motor running during the setting.

此項設定只要開啟發射器，接上BEC電源即可進行操作。注意：為了安全起見，設定前請先不要將無刷調速器與無刷馬達三條線接上，以免調整時啟動馬達而發生危險。

SERVO CONFIGURATION 伺服器配置

Following the servo configuration diagram on right, plug the servos to Gyro.

請依照右圖顯示的伺服器名稱，將伺服器接到陀螺儀。



ADJUSTMENTS FOR GYRO AND TAIL NEUTRAL SETTING

陀螺儀與尾翼中立點設定調整

Turn off Revolution mixing(RVMX) mode on the transmitter, then set the gain switch on the transmitter and the gyro to non-head lock mode, or disable gain completely. After setting the transmitter, connect the helicopter power and proceed with rudder neutral point setting.

Note: When connecting to the helicopter power, please do not touch tail rudder stick and the helicopter, wait for 3 seconds for gyro to enable, and the rudder servo horn should be 90 degrees to the tail servo. Tail pitch slider should be halfway on the tail output shaft. This will be the standard rudder neutral point. After completing this setting, set the gain switch back to heading lock mode, with gain at around 70%.

發射器內陀螺儀設定請轉軸鎖開模式，並將發射器上的增益開關與陀螺儀切換至“非鎖定模式”或將陀螺儀增益關閉。發射器設定完成後接上直升機電源，即可進行尾翼中立點設定。

注意：當接上直升機電源時請勿碰動尾桿或直升機機體，待3秒陀螺儀開機完成後，尾舵伺服器與尾舵伺服器成 90 度，尾舵翼控制組須正確置於尾舵輸出軸中間位置，即為標準尾翼的中立點設定，設定完成後，切換至“鎖定模式”，將增益約 70% 左右。

TAIL NEUTRAL SETTING 尾翼中立點設定

After the gyro is enable and under non-head lock mode, correct setting position of tail servo and tail pitch assembly is as photo. If the tail pitch assembly is not in the middle position, please adjust the length of rudder control rod to trim.

陀螺儀開機後，在非鎖定模式下，尾舵伺服器與 Tail Pitch控制組正確擺置位置。若尾 Pitch控制組未置於中間位置應將尾舵控制桿的長度來修正。

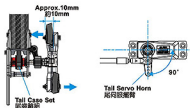

HEAD LOCK DIRECTION SETTING OF GYRO 陀螺儀鎖定方向設定

To check the head lock direction of gyro is to move the tail clockwise and the tail servo horn will be trimmed counterclockwise. If it trims in the reverse direction, please switch the gyro to "REVERSE".

陀螺儀鎖定方向設定，當手尾舵控制組轉動時，尾舵伺服器應反時鐘修正，反方向時請切換陀螺儀上“鎖定方向”開關修正。





The maximum speed of TB40 helicopter is 3400RPM; 3150RPM is enough for hard 3D flight.

It is strictly forbidden to set the Main Blades speed to exceed **3400RPM** during flight, over-rotation may cause damage to the body structure or unforeseen danger, even lives and property of others.

Beginner are recommended the RPM/ speed setting should not exceed **2750RPM**.

TB40 直昇機，最高轉速為3400RPM；飛行時轉速3150RPM，動力已足夠暴力飛行。

直昇機的主旋翼有安全使用轉速範圍，飛行時主旋翼轉速設定嚴禁超過**3400RPM**，超轉可能導致機體結構破壞及不可預期之意外，甚至危害他人生命財產。

初學者建議轉速設定不超過**2750RPM**。

POWER COLLOCATION REFERENCE 原裝動力數據參考表

RCM-BL400MX (1100KV/3220) MOTOR 無刷馬達

KV	KV值	1100KV(RPM/V)	Input Voltage	輸入電壓	6S
Stator Diameter	定子外徑	32mm	Stator Thickness	定子厚度	20mm
Stator Arms	矽鋼片槽數	9	Magnet Poles	磁極槽數	6
Max Continuous Current	最大持續電流	50A	Max Instantaneous Current	最大瞬間電流	75A(2sec)
Max Continuous Power	最大持續功率	1110W	Max Instantaneous Power	最大瞬間功率	1660W(2sec)
Dimension	尺寸	Shaft $\phi 5 \times 40.9 \times 63.8$ mm	Weight	重量	Approx. 176g

SPECIFICATION

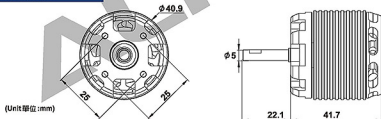

ILLUSTRATION 接線示意圖



The motor rotates in different direction with different brand ESCs. If the wrong rotating direction happens, please switch any two cables to make the motor rotates in right direction.

由於各品牌電子變速器的馬達啟動轉向不盡相同，若發生轉向錯誤時，請將馬達與電子變速器的接線任兩條對調即可。

BRUSHLESS SPEED CONTROLLER INSTRUCTION MANUAL

無刷調速器使用說明



RCE-BL60A Brushless ESC can be set up by ALIGN ASBOX Multifunction Programmer. So please scan QR code for ALIGN website start downloading for more information:
<http://www.align.com.tw/download-en/asbox/>

RCE-BL60A無刷調速器可透過ALIGN ASBOX 多功能設定盒進入參數設定，請掃描QR Code 連結至拓網站下載相關資訊：<https://www.align.com.tw/index.php/download/asbox/>

- The default throttle range of this ESC is from 1100 μ s to 1940 μ s, so you need to re-calibrate the throttle range when the first time you use this ESC or after you replace the transmitter.
 - During the ESC/Receiver calibration, please set the throttle curve to NORMAL and ensure the corresponding throttle amounts to the maximum throttle endpoint and the minimum throttle endpoint on your transmitter are respectively 100% and 0%.
1. 電子調速器的油門行程出廠預設值為1100 μ s ~ 1940 μ s，當首次使用電子調速器或者更換其他遙控器使用時，均應重新設定油門行程。
 2. 進行油門行程校準時，請將油門曲線設定為NORMAL，並確保遙控器油門最高點對應的油門值為100%，油門最低點對應的油門值為0%

RCE-BL60A BRUSHLESS ESC 無刷調速器

- RPM Signal Wire (Yellow):** plug it into the RPM input channel on the flybarless system. (This wire can be used for providing RPM signal data when using external speed-governing device, plug it into the battery channel or any unoccupied channel on the receiver. (For better BEC power supply, we recommend plugging this wire into the battery channel or any unoccupied channel on FBL system if the FBL system is permitted.
 - Throttle Signal Wire (White/Red/Black):** plug it into the throttle channel on the receiver or the corresponding channel on the FBL system, such as RX B channel on the VBAR system. For which channel you should plug it in, it depends on what kind of receiver and FBL system you use. The White wire is for transmitting throttle signals, the Red & Black cables are parallelly connected in the BEC output wire, which means BEC voltage output wire and ground cable.
1. RPM信號線(黃)：插入無平衡翼系統轉速輸入通道。(當使用外部定速時，可使用RPM信號線提供轉速信號輸入，這條線外的BEC輸出線插入接收機電池專用通道或任意空閒通道。(為獲得更好的BEC供電效果，在無平衡翼系統允許的情況下，建議將BEC線插入無平衡翼系統的電池專用通道或在空閒通道。)
 2. 油門信號線(白、紅、黑)：插入接收機油門通道或無平衡翼系統對應通道，如VBAR系統的RX B通道，依據接收機型及無平衡翼系統類型而定，其中白線用於傳送油門信號，而紅線和黑線分別並聯在內部BEC的輸出端(即BEC電壓輸出線和地線)。

I. Connections 接線示意圖

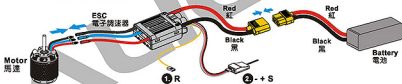

Model 型號	RCE-BL60A Brushless ESC RCE-BL60A無刷調速器
Input Voltage 輸入電壓	3-6S LiPo Battery 3-6S鋰電池
Cont./Peak Current 持續/峰值電流	60A/80A
Throttle Signal/BEC Output & RPM Signal Transmission Wire 油門信號/BEC輸出&RPM信號傳輸線	White: Throttle Signal Wire / Red/Black: BEC Output ; Yellow: RPM Signal Transmission Wire 白色為油門信號線、紅黑二色線為BEC輸出線、黃色為RPM信號傳輸線。
Size/Weight 尺寸/重量	48.0x30.0x15.5mm/49g

II. Throttle Range Calibration 油門行程校準操作方法

- Turn on the transmitter and move the throttle stick to the top position.
開啟遙控器，將油門打到最高點
- Connect the ESC to a battery. The motor will emit "123" indicating the ESC is powered on normally.
電子調速器接電池，電源開機，"123"提示音，表示供電正常
- 5 seconds later, the motor will emit two short beeps indicating the maximum throttle position has been successfully calibrated and accepted.
等待5秒，馬達發出"啾-啾"雙短音響，表示油門最高點校準成功
- Move the throttle stick to the bottom position. 1 second later, a short beep will emit indicating the minimum throttle position has been accepted.
將油門桿拉到底部，等待1秒，"啾"一聲提示音，油門最低點校準成功
- The ESC will keep beeping indicating the number of LiPo cells you have plugged in. (A long beep represents 5, a short beep represents 1. E.g. The ESC will beep two long beeps and two short beeps to indicate a 12S LiPo pack.
馬達將繼續提示音告知電池電壓 (長短音響代表5，短音響代表1，例如：12S電池將提示"啾-啾-啾-啾")
- The motor will beep a long beep to indicate the calibration is completed, the power system is ready to go.
馬達將提示"長音響"，表示校準成功，系統準備就緒，可開始定速



Maintenance and careful inspection before and after flights are the most important part of flight safety, pilots are responsible for every detail to implement. Negligence of these inspections and maintenance may lead to accidents and dangers during the flight, and even damage to life and property.

飛行前後的仔細檢查和維護保養是飛行安全最重要的一環，飛行員必須對每一個細節負責並落實到位。忽視這些檢查和維護，可能會導致飛行過程中發生事故和危險，甚至造成生命財產損失。



1 Check the Main blades.

Visually inspect if the appearance of the Main Blades is good, and carefully check that there is no damage, crack or abnormality on the surface.

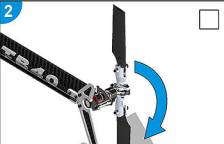

2 Check the Tail Blades.

Visually inspect if the appearance of the Tail Blades is good, and carefully check that there is no damage, crack or abnormality on the surface.

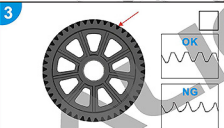

Please check to the main gear regularly, and replace it if obvious wear is found. The main gear is a consumable.

Please pay attention to check and replace new gears every 100 times of 3D sport flight.



4 Check All electronic equipment connection.

Plug, socket and cable appearance is good, correctly and firmly connected with each other.

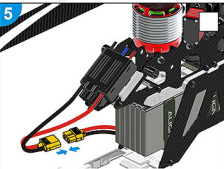





5 Check battery efficiency.

To prevent the plug from falling off and causing power failure, the plug and socket must be connected firmly.

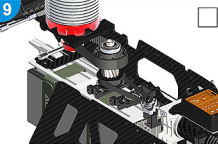
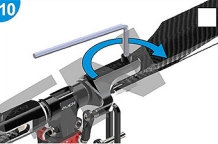

6 Check linkage rod and ball of main rotor head and tail rotor head.

Slightly shake linkage ball by hand. It's normal if you can't shake it; however, it's abnormal if it's shaken a lot and must be replaced the new linkage and linkage balls to prevent loose parts for any flight error and danger.

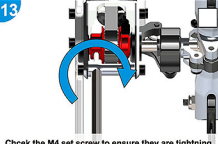
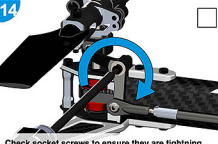
<p>7 <input type="checkbox"/></p>  <p>Obverse of Bearing Faces Inside. 給承面凹溝口朝內。</p> <p>Thrust Bearing 止推軸承</p> <p>Check thrust bearing and bearing of main rotor holder. Check if there is wear or damage of thrust and bearing. Bearing should be smooth enough. If anything is worn, it must be replaced immediately. Please follow the Instructions for thrust bearing assembly. Any incorrect assembly will result in flight error.</p>	<p>8 <input type="checkbox"/></p>  <p>One-way Bearing 单向轴承</p> <p>Logo on the top 字標朝上</p> <p>Check one-way bearing is rotated well and apply a little amount of grease on it for maintenance.</p>
<p>9 <input type="checkbox"/></p>  <p>Before each flight, be sure to check the adjustment and check the belt tightness.</p>	<p>10 <input type="checkbox"/></p>  <p>Check the socket collar screws of Main Blades to ensure they are tightening.</p>
<p>11 <input type="checkbox"/></p>  <p>Check the M4 nut screws to ensure they are tightening</p>	<p>12 <input type="checkbox"/></p>  <p>Check Tail assembly screws to ensure they are tightening.</p>
<p>13 <input type="checkbox"/></p>  <p>Check the M4 set screw to ensure they are tightening.</p>	<p>14 <input type="checkbox"/></p>  <p>Check socket screws to ensure they are tightening.</p>

	Problem 狀況	Cause 原因	Solution 對策
Blade Tracking 雙槳平衡	Tracking is Off 雙槳	Pitch linkage rods are not even length PITCH連桿長度調整不平均	Adjust length of Linkage rod A. 調整連桿A長度
Rudder Response 尾舵反應	Drifting of tail occurs during hovering, or delay of rudder response when centering rudder stick. 停機時尾翼向某一側偏移，或啟動方向舵並回復到中立點時，尾翼產生延遲，無法停頓在所設制位置上。 Tail oscillates (hunting, or wags) at hover or full throttle 停機或在全門時尾翼左右來回搖擺。	Rudder neutral point improperly set 尾中立點設定不當	Reset rudder neutral point 重設尾中立點
		Rudder gyro gain too low 尾舵陀螺儀感度偏低	Increase rudder gyro gain 增加尾舵陀螺儀感度
		Rudder gyro gain too high 尾舵陀螺儀感度偏高	Reduce rudder gyro gain 降低尾舵陀螺儀感度

If above solution does not resolve your issues, please check with experienced pilots or contact your Align dealer.
※在完成以上調整後，仍然無法改善情況時，應立即停止飛行並向有經驗的飛手諮詢或連絡您的經銷商。

FLIGHT NOTE

1. Helicopter and related equipment should be maintained on a regular schedule.
2. Make sure to check flight and record it every time. This record would be helpful for your future reference of maintenance and repaired.
3. Pre-flight and after flight, please deliberately check if every spare parts and electronic equipment work well and no damage.
4. Please strictly do every inspection and check the screws are locked well, not loose at all, before flight.
5. Regular maintenance recommendations: Replace thrust bearings every 30 hours of flight. Replace the main shaft fixed bearing(6901ZZ) and main rotor clamp bearing(6800ZZ) every 60 hours of flight. When the number of flights exceeds 100, please carry out regular maintenance of the entire aircraft and replace parts (such as bearings and washers) to ensure flight safety.
6. For more operation introduction, please read the instruction manual carefully and obey the local regulations.

飛行小叮嚀：

1. 飛行機及相關設備均需要定期維護保養！
2. 每次檢查保養應確實紀錄，良好的保養檢查及飛行習慣，將會提供您日後維修或更換耗材的參考及幫助。
3. 飛行前、及飛行後，務必詳細檢查機身各部位零件／電子設備之性能是否正常，而且無損耗老化現象。
4. 請嚴格執行檢查的義務，飛行前應檢查螺絲確實鎖緊沒有鬆動，才能升空飛行。
5. 定期保養建議：每飛行30小時，更換止推軸承。每飛行60小時更換主軸固定軸承、主旋翼夾軸承。
6. 飛行次數超過100組時，請進行全機定期保養並更換零件(如軸承類及墊圈等消耗品)，以確保飛行安全。
7. 更多詳細操作介紹，請參閱使用說明書，並且遵守當地法規。

Thank you for purchasing and supporting ALIGN products.

The Align Team is dedicated to you by innovating and developing new RC Helicopters, Multicopters, and FPV Racing Quads. We strive to provide a more diversified experience for our customers. Visit our website at www.align.com.tw for latest news, information, and updates about our extensive line of products for the RC enthusiasts.

Good Flying!

再次感謝您對亞拓系列商品的喜愛與支持，您的肯定是對我們最大的認同。

亞拓團隊秉持創新研發的精神，開發遙控直昇機／多軸飛行機／穿越機系列商品，提供給您體驗更多樣化的飛行樂趣。您可以透過下列連結，隨時瞭解亞拓的最新動態，以及各項訊息分享。

祝願您有一個愉快的飛行體驗。



ALIGN Flight Safety
亞拓飛行安全宣導



ALIGN Shopping Cart
亞拓購物車



facebook
ALIGN FaceBook



ALIGN Website
亞拓官網



ALIGN Quick Finder
亞拓零件快速購



YouTube
ALIGN YouTube

STANDARD EQUIPMENT

Equipment	Versions	Top Combo	Kit
Illustration			
Brushless Motor		RCM-BL400MX(1100KV/3220)	RCM-BL400MX(1100KV/3220)
Brushless ESC		60A Brushless ESC	_____
Cyclic Servo		DS450M x3	_____
Tail Servo		DS535M	_____
Flybarless System		Microbeast Flybarless System	_____
Main Blade		380 Carbon Fiber Blades	380 Carbon Fiber Blades
Tail Blade		70 Carbon Fiber Tail Blades	70 Carbon Fiber Tail Blades
Motor Belt Pulley		22T	22T
Drive Gear Ratio		6.44 : 1 : 4.04	6.44 : 1 : 4.04
Max RPM (approx.)		3400RPM	_____

SPECIFICATION

Equipment	Versions	Top Combo	Kit
Length		747mm	747mm
Width		103mm	103mm
Height		223mm	223mm
Main Blade Length		380mm	380mm
Main Rotor Diameter		851mm	851mm
Tail Length		70mm	70mm
Tail Rotor Diameter		188mm	188mm
Frame Weight		953g	953g



一、遙控無人機產品標示

本產品最大起飛重量：1.3 公斤	(1)
<input checked="" type="checkbox"/> 應 <input type="checkbox"/> 免 依遙控無人機管理規則至民航局「遙控無人機規範管理系統」(https://drone.caa.gov.tw/) 進行線上註冊，註冊號碼應標明於機身顯著處。	(2)
<input checked="" type="checkbox"/> 應 <input type="checkbox"/> 免 具備航空站或飛行場圖資軟體功能。	(3)
<input type="checkbox"/> 具型式檢驗(認可)標章且應向民航局申請辦理實體檢驗。 <input checked="" type="checkbox"/> 免辦理檢驗或認可。	(4)(5)
操作人 <input type="checkbox"/> 免持操作證 <input type="checkbox"/> 應持普通操作證 <input checked="" type="checkbox"/> 應持專業操作證。	(6)
操作本產品前，經檢查確保符合飛航安全條件後從事活動，並禁止飲酒或使用影響精神之藥物，亦不得於公告禁止或限制區域飛航，其餘請詳參見本產品所附操作手冊說明。	(7)(8)
違反上述規定者，中央及地方主管機關得依民航法禁止其活動，並處以新臺幣1萬至150萬元罰鍰，情節重大者沒收及遙控無人機。	(9)(10)
本標示依據遙控無人機管理規則第17條第1項規定辦理。	(11)

二、遙控無人機相關法規說明：

- 遙控無人機管理規則(以下稱管理規則)第6條第1項：自然人所有之最大起飛重量250公斤以上之遙控無人機及政府機關(構)、學校或法人所有之遙控無人機，應由其所有人向民航局申請註冊，並將註冊號碼標明於遙控無人機上顯著之處後，始得操作。
- 管理規則第9條：註冊號碼應依下列方式標明於遙控無人機上顯著之處：一、以標機、機頭、機尾或其他所稱之方式標明，且應確保每次飛航活動時不至脫落並保持清潔、明顯使用辨識。二、標機位置應為遙控無人機之固定結構外部。三、其顏色應與註冊號碼與背景明顯反差，且以內嵌即能視覺。
- 管理規則第12條第1項：最大起飛重量1公斤以上且裝置導航設備之遙控無人機，應具備防止遙控無人機進入禁航區、限航區及航空站或飛行場四圍之一定距離範圍之電子防撞系統，其距離應符合本法第4條制定及第99條之13第1項公布之範圍。
- 管理規則第13條：遙控無人機之設計、製造、改裝，應由設計者、製造者或改裝者檢附申請書向民航局申請型式檢驗，經型式檢驗合格者，發給型式檢驗合格證，並加蓋型式檢驗標章。自國外進口之遙控無人機，應由進口者依第一項規定向民航局申請型式檢驗，或檢附申請書向民航局申請認可。經認可者，發給認可證明文件及型號標章。前二項之遙控無人機，其型式標章應單附民航局公告者，應免辦理檢驗或認可。
- 管理規則第15條第1項：最大起飛重量25公斤以上之遙控無人機，為確保遙控無人機符合設計、製造、改裝之性能單元，應由其所有人檢附申請書向民航局申請實體檢驗，經檢驗合格者，發給實體檢驗合格證。
- 管理規則第20條：遙控無人機操作證分類、申請者年齡及其他規定如下：
A. 普通操作證：申請者年滿16歲，經申請後，由民航局發給。
B. 專業操作證：申請者年滿18歲，經專業測驗合格後，由民航局發給。
C. 專業師範操作證：申請者年滿18歲並符合相關師範規定後，經測驗合格後及學、術科測驗合格後，由民航局發給。
前項各類操作證之操作權限如下：一、普通操作證：持有人得於遙控無人機普通操作證或專業操作證之操作人在旁指導下，依其得為操作證或專業操作證所載之範圍飛行，學習操作最大起飛重量未達二十五公斤之遙控無人機。二、普通操作證：持有人得操作自本人所有最大起飛重量二公斤以下、未達二十五公斤且裝置導航設備之遙控無人機。三、專業師範操作證：持有人得操作政府機關(構)、學校或法人所有之遙控無人機及自然人所有最大起飛重量十五公斤以上之遙控無人機。
- 管理規則第25條：操作人操作遙控無人機應遵守下列事項：一、自檢中酒後不得操作百分之0.02或吐氣中酒精濃度不得超過每公升0.1毫克。二、不得受酒精作用實質影響，導致行為能力受到損傷。三、不得對任何生命財產造成危險或造成他人之生命財產。
- 管理規則第26條：操作人從事遙控無人機飛航活動前，應依遙控無人機製造者所提供之維修指引對遙控無人機系統進行檢查，符合安全飛航條件後始得活動。
- 民用航空法遙控無人機專章第119條之1：遙控無人機之所有人或操作人有下列情事之一者，由民航局應禁止其操作證，並處新臺幣30萬元以上150萬元以下罰鍰，並得沒收遙控無人機：一、違反第99條之13第1項規定，於禁航區、限航區及航空站或飛行場四圍之一定距離範圍內從事飛航活動。二、違反第99條之14第1項第1款規定，違距地空或高度400呎從事飛航活動。
- 民用航空法遙控無人機專章第119條之2：遙控無人機之所有人或操作人有下列情事之一者，禁止其活動，並處新臺幣6萬元以上30萬元以下罰鍰；情節重大者，並得沒收遙控無人機：一、違反第99條之10第1項有關遙控無人機註冊或標明註冊號碼之規定。二、違反第99條之10第2項規定，未領有操作證而操作遙控無人機。三、違反第99條之15第3項規定，未投保或未定額投保責任保險而從事遙控無人機活動。遙控無人機之所有人或操作人有下列情事之一者，禁止其活動，並處新臺幣3萬元以上15萬元以下罰鍰；情節重大者，並得沒收遙控無人機：一、違反第99條之10第1項有關遙控無人機註冊或標明註冊號碼之規定。二、違反第99條之13第2項有關直轄市、縣(市)政府公告時間、時間及其他管理事項之規定。三、違反第99條之14第1項第2款至第10款遙控無人機飛航活動應遵守之規定。本條規定之處罰，除同時違反第99條之13第1項或第99條之14第1項第1款由民航局處罰外，由直轄市、縣(市)政府處罰之。
- 民用航空法遙控無人機專章第119條之3：違反第99條之17所定規則有關制動測試、檢驗、認可、維修與檢查、飛航活動之活動許可及內容、製造者與進口者之義務及責任、飛航安全相關事件之通報等事項規定者，禁止其活動，並處新臺幣1萬元以上150萬元以下罰鍰；情節重大者，並得沒收遙控無人機。

※有疑後請逕洽遙控無人機法規最新資訊，請詳見：(<https://drone.caa.gov.tw/>) 或掃描右方QR Code連結。



感謝您購買亞拓系列商品，謹表謝意！

- 亞拓E1偵查直昇機、M4/M6偵察多軸機、M460/M490/M470L/M480XL/M690L空拍/任務無人機、屬「商業導航無人機」，與國內已有預先登記資料，操作者可直接於交通部民用航空局無人機專區註冊完後，登錄系統下預備型號即可登錄完成註冊程序。
- 亞拓T-REX系列E1空拍機、AMR25XP穿越機/多旋翼空拍機系列商品，其屬於「自製無人機(含航空模型機)」，須先向自行辦理型號登記作業。
- 相關型號、構造、尺寸(長×寬×高)、飛機實重/自昇機購買半徑/多變質軸距、使用動力、導航方式一詳細資訊，請連結右側QR Code「亞拓無人機註冊資訊」，或參考「亞拓無人機註冊教學」直行登錄註冊。



Memo



www.align.com.tw

www.align.com.tw

www.align.com.tw

www.align.com.tw

www.align.com.tw

www.align.com.tw

www.align.com.tw



TREX TEAM ALIGN

亞拓科技股份有限公司
ALIGN CORPORATION LIMITED MADE IN TAIWAN

2024.Feb.06 G00787